

Química E – Extensivo – V. 7

Resolva

Aula 25

25.01)A

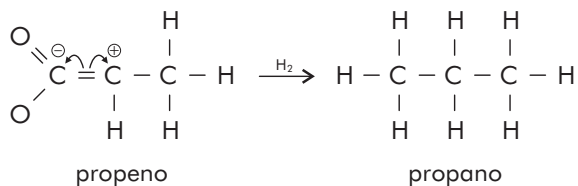

Aula 26

26.01) Não. A adição de água a alcinos sempre dá origem a cetonas, exceto o acetileno, que forma aldeído.

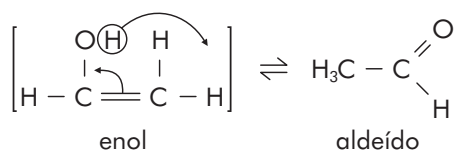
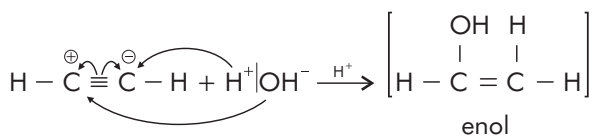

26.02)A adição de HBr a alcenos, na presença de peróxido, segue a regra de Karasch e Mayo ou anti-Markownikoff (o H ataca o carbono menos hidrogenado)

Exemplo:

Exceto

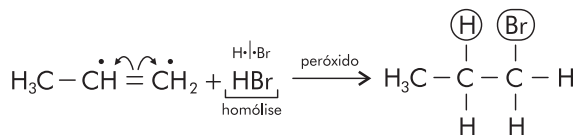

Geral:

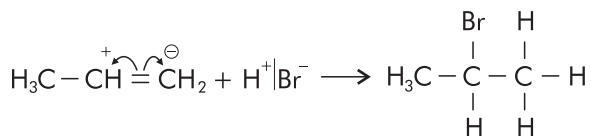

Regra Markownikoff

Aula 27

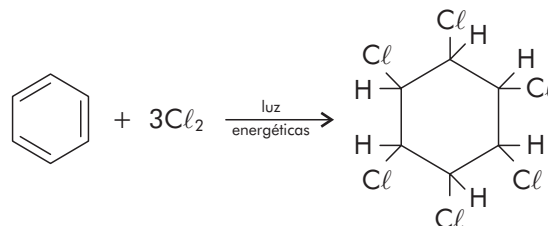
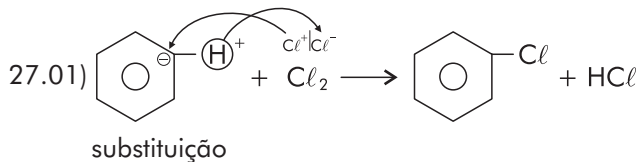

adição (+ energética)

Aula 28

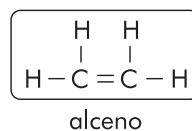
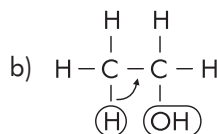
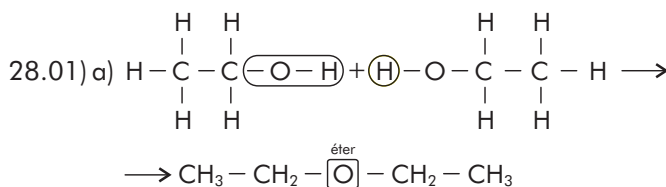

Testes

Aula 25

25.01) 20

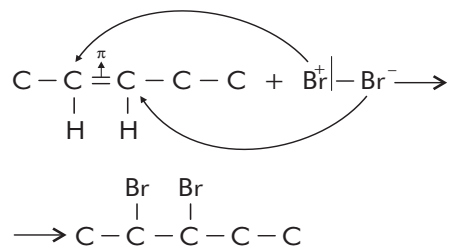

\left\{ \begin{array}{l} \text{dialeto vicinal} \\ \text{2,3-dibromopentano} \end{array} \right.

25.02) 6 hidrogênios

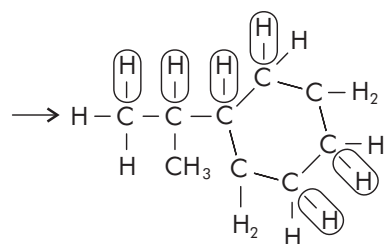
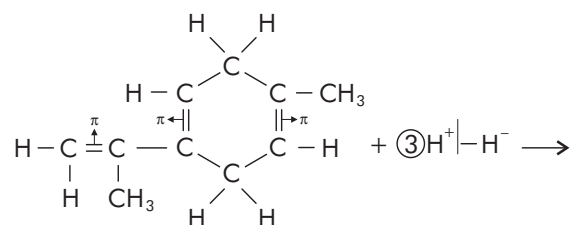

25.03) B

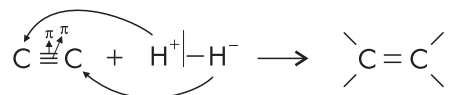
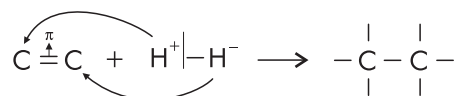

(Sabatier – Senderens)

25.04) butano

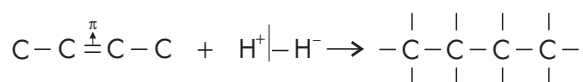

25.05) A

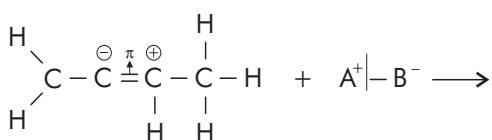

25.06) 23

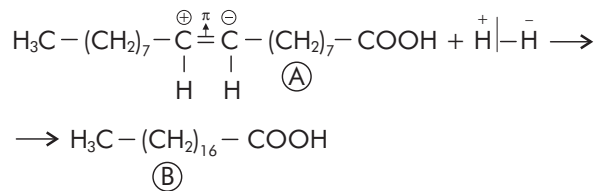

01. Correto.

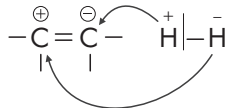

02. Correto.

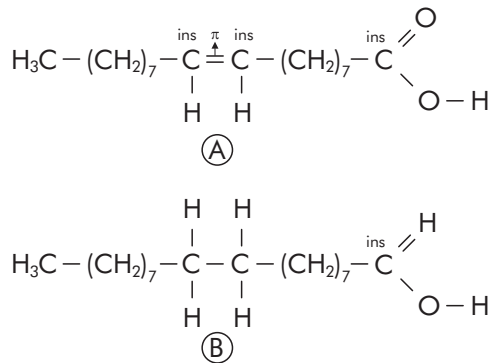

04. Correto.

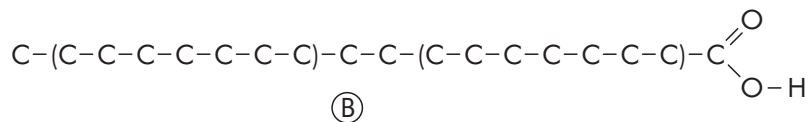

08. Incorreto.

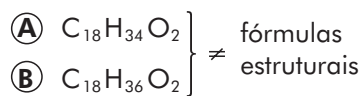

16. Correto.

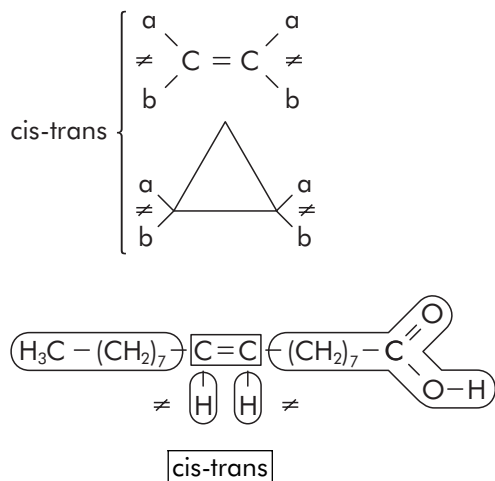

25.07) 29

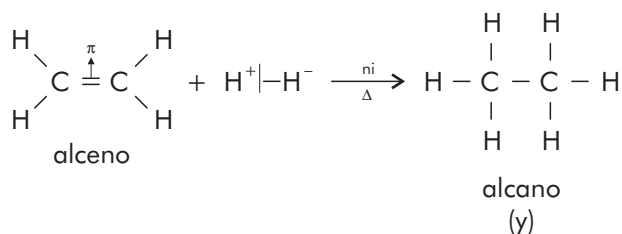

01. Verdadeira.

02. Falsa.

04. Verdadeira.

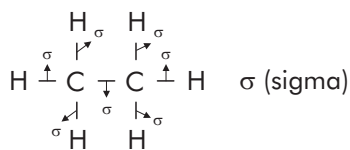

08. Verdadeira.

16. Verdadeira.

25.08) 02

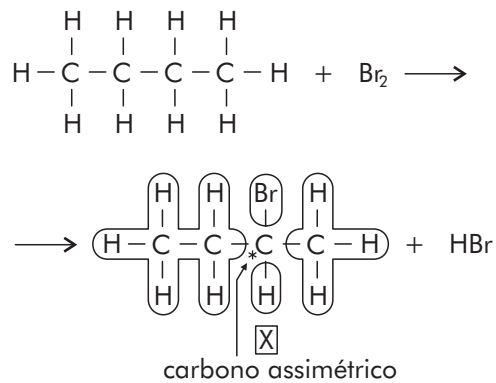

$$2^1 = 2 \begin{cases} \text{d (dextro)} \\ \text{l (levo)} \end{cases}$$

isomeria óptica (tipo de isomeria espacial)

25.09) A

Sabatier-Senderens (= ou \equiv)

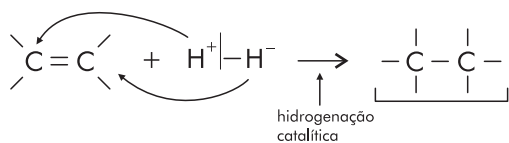

25.10) D

A reação característica dos alcanos é a substituição por **radicais livres**. (RSR)

25.11) C

compostos insaturados (= ou \equiv)
ligações π (nuvens)

25.12) E

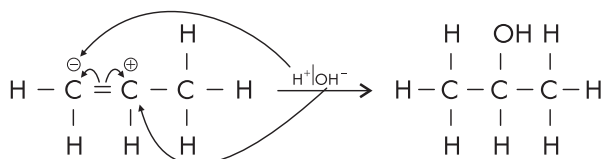

2-propanol

25.13) 2-metil-2-butanol

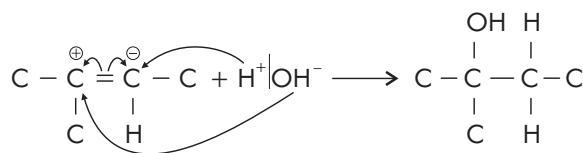

25.14) 2-metil-2-propanol

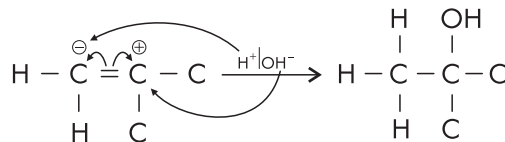

25.15) D

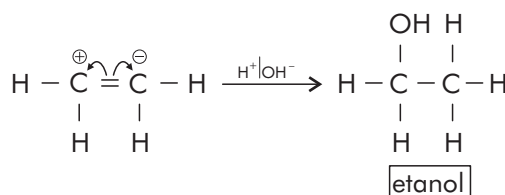

25.16) C

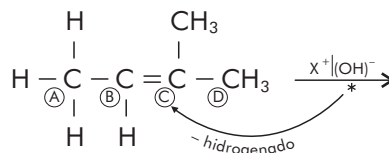

carbono \oplus hidrogenado da dupla $\Rightarrow \text{C}^\ominus$
carbono \ominus hidrogenado da dupla $\Rightarrow \text{C}^\oplus$

25.17) hidrogenação catalítica

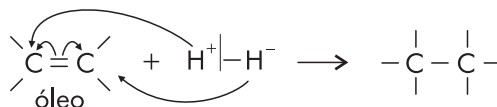

25.18)

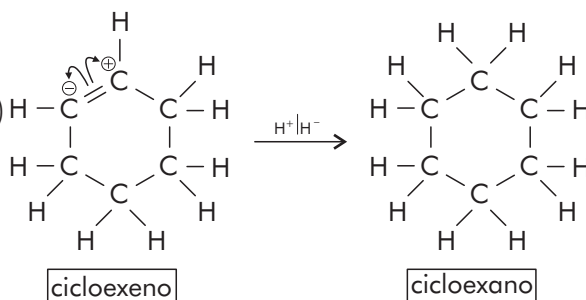

Aula 26

26.01)A

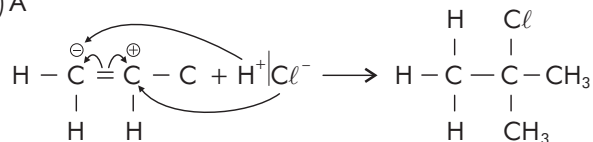

2-cloro-2-metilpropano

26.02)C

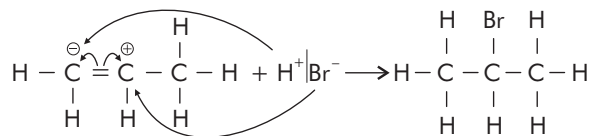

2-bromopropano

26.03)E

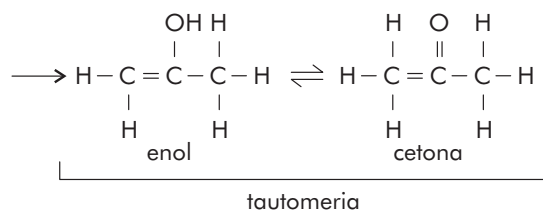
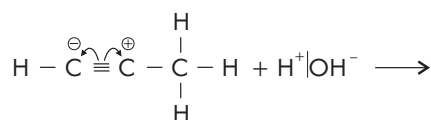

26.04)A

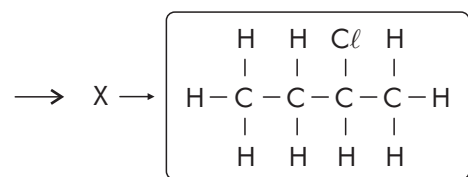
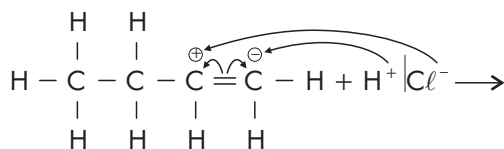

26.05)B

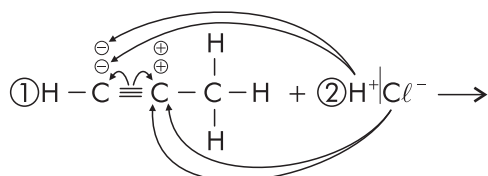

Quebrar as duas ligações π da tripla

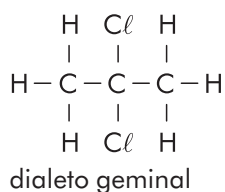

26.06)B

aldeídos e cetonas

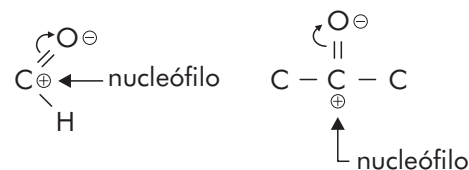

reação de adição nucleofílica (RAN)

26.07)A

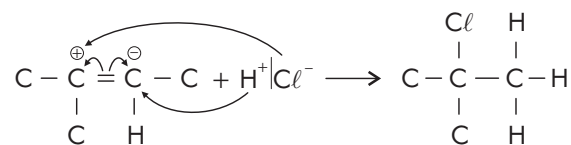

26.08)B

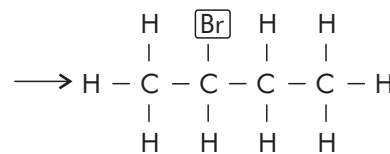
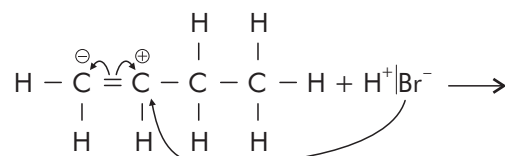

brometo de sec-butila

26.09)D

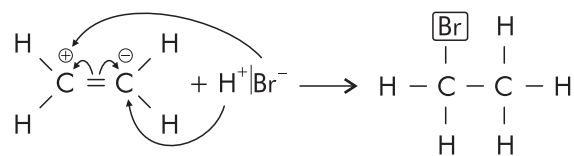

adição eletrofílica

26.10)A

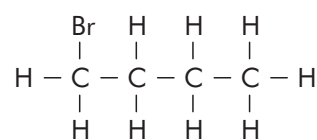
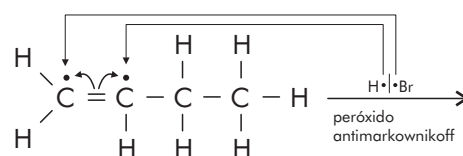

brometo de butila

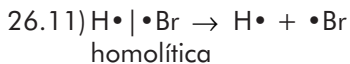

26.12) 15

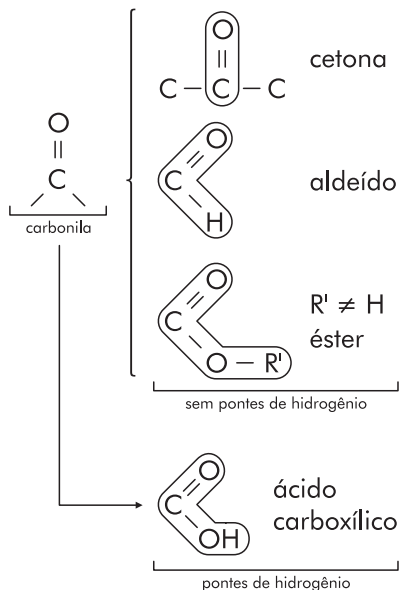

01. Verdadeira.
02. Verdadeira.

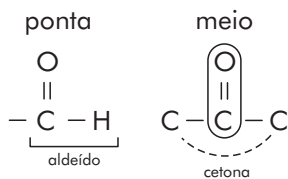

04. Verdadeira.

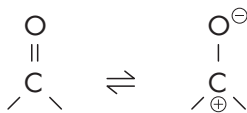

08. Verdadeira.

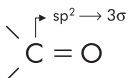

16. Falsa.

26.13) B

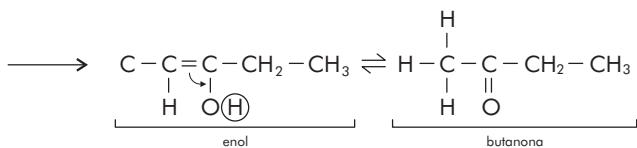
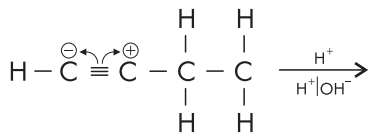

26.14) E

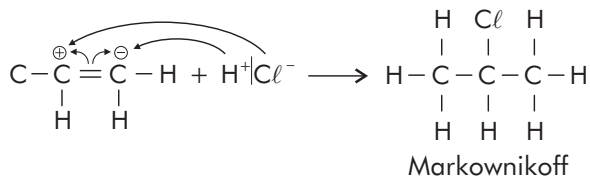

26.15) A

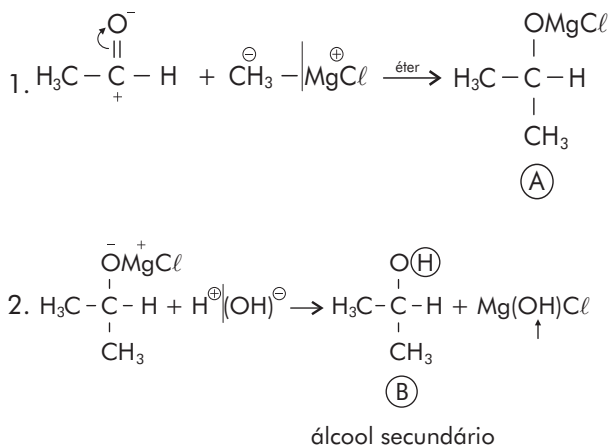

26.16) 05

A) $\text{H}^+ | \text{Br}^-$

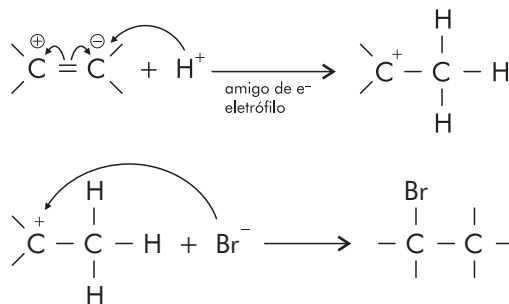

B) $\text{H}_3\text{C}-\text{C}^+=\text{O} + \text{H}^+ + \text{CN}^- \rightarrow$
amigo de núcleo nucleófila

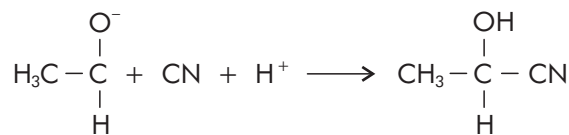

A \Rightarrow adição eletrófila
B \Rightarrow adição nucleófila

26.17) C

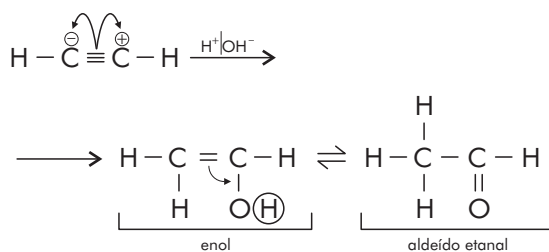

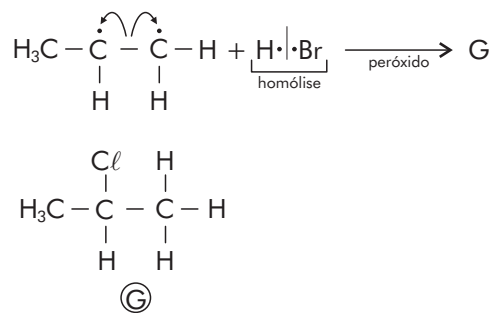
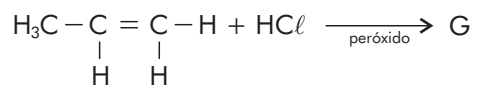
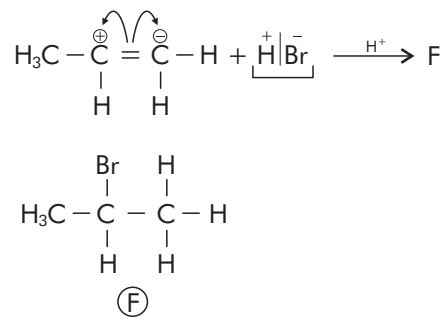
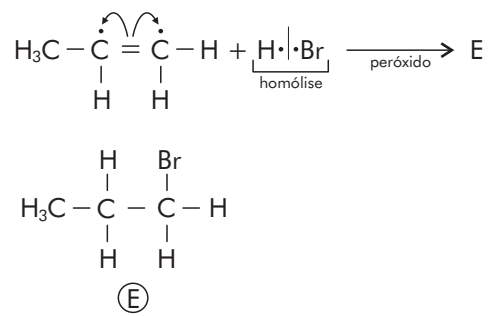
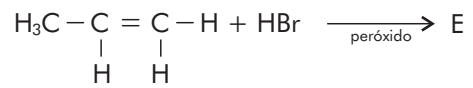
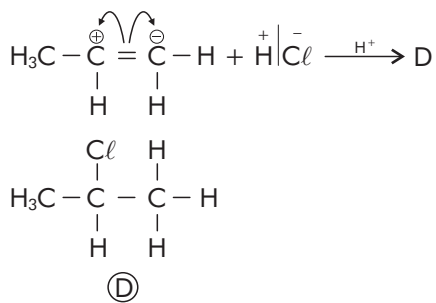
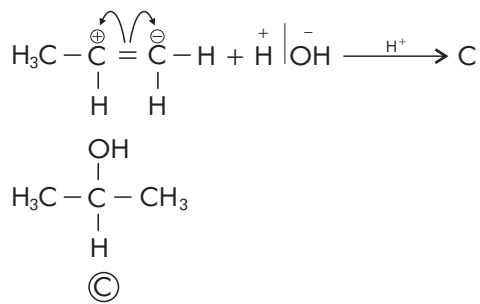
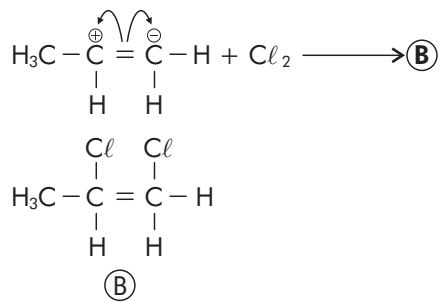
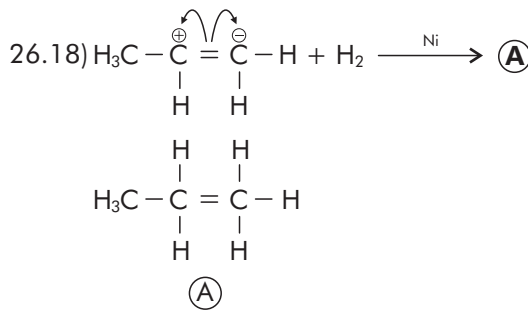

Aula 27

27.01) D



60°

+ reativo
+ tensão
- estável

27.02) C



60°

⊕ reativo

⊖ estável



90°

⊖ reativo

⊕ estável



108°

27.03) A

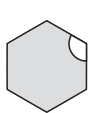

109°28'

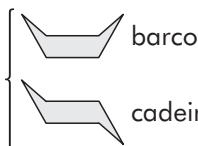

27.04) E

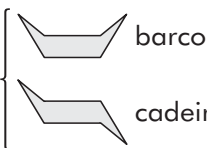
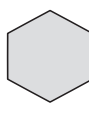

27.05) A

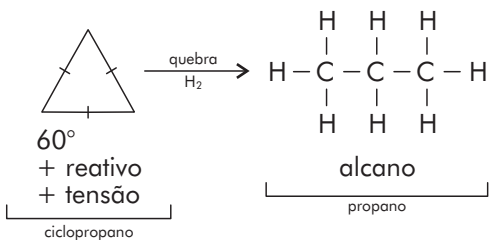

27.06) A

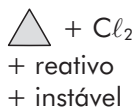

27.07) D



60°

+ tensão
+ reativo
- estável



90°



108°

- tensão
- reativo
+ estável

27.08) C

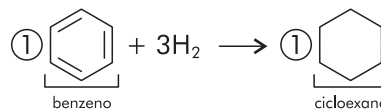

27.09) E

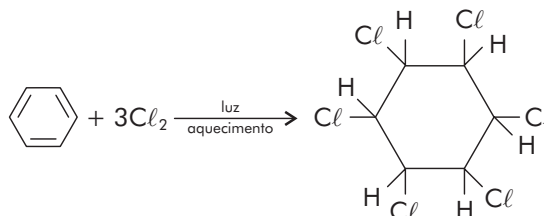

27.10) O maior erro de Bayer foi ter considerado todos os compostos planares, o que ocorre até cinco carbonos. Com seis carbonos, os ciclanos são não-planares e possuem duas configurações possíveis; uma em forma de barco e outra de cadeira.

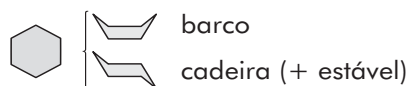

60°

+ tensão
reação de adição



90°

+ tensão
reação de adição

27.12) 5 isômeros planos monoclorados

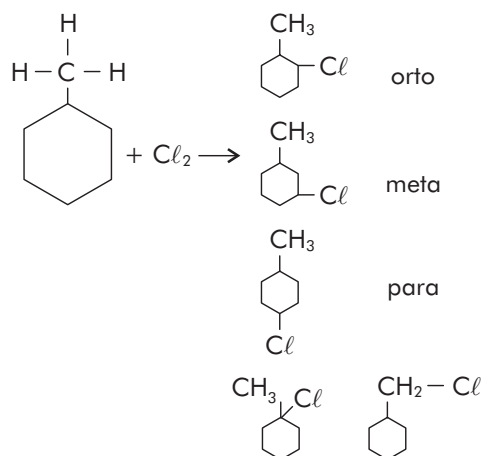

27.13) substituição

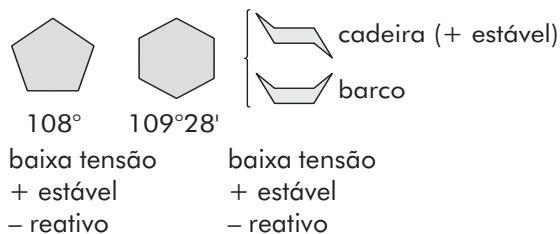

28.11) A

O hidrogênio eliminado deve ser do carbono vizinho da oxidrila (OH) menos hidrogenado.

28.12) D

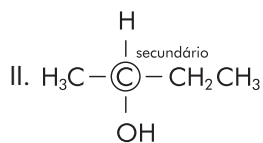
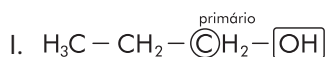

Terciário > Secundário > P

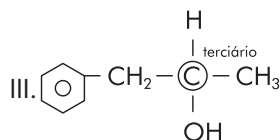

28.13) B

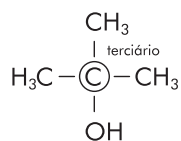
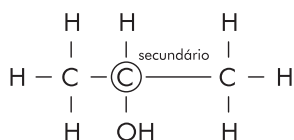
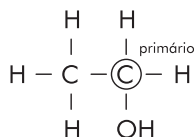

28.14) D

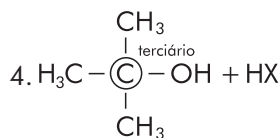
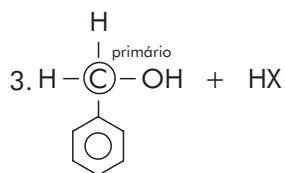
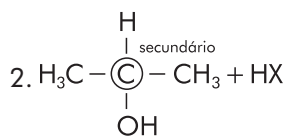

+ reativo

carbono terciário > carbono secundário > carbono primário > carbono primário

- reativo

ligado no 

28.15) D

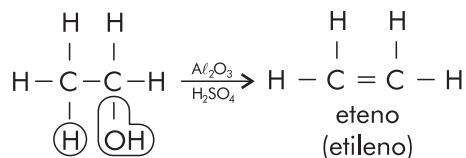

28.16) A

intramolecular

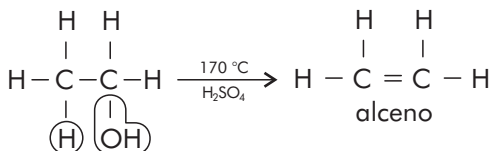

intermolecular

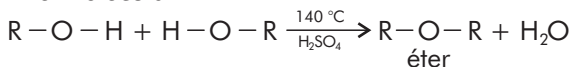

28.17) B

terc > secundário > primário

28.18) 18

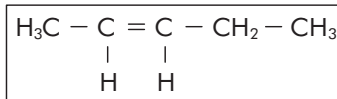
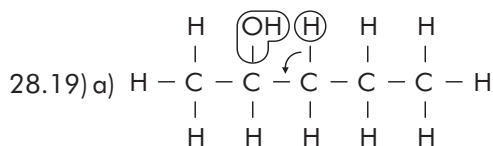
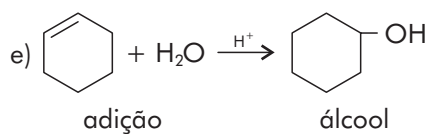
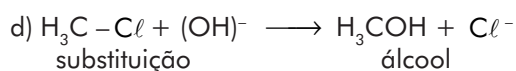
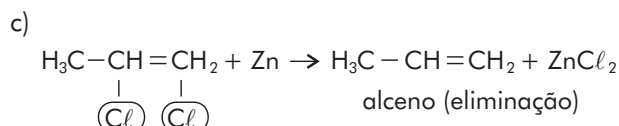
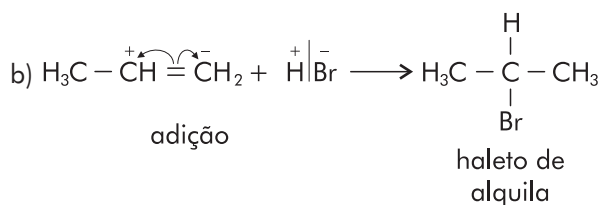
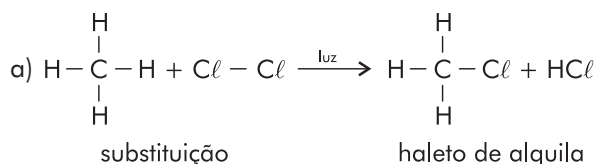

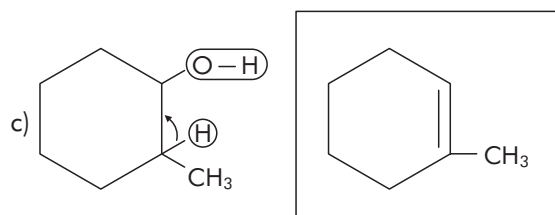
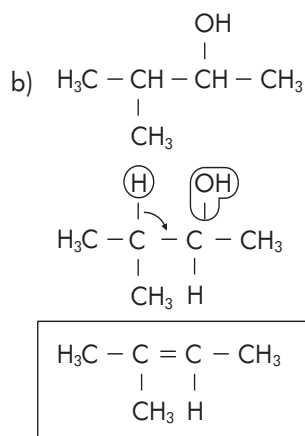

28.20) Porque o éter etílico é obtido pela desidratação intramolecular de etanol por meio do ácido sulfúrico – daí o nome.

